

# 11144 - TH MDL 200 'P' TYPE 16mm SPIGOT

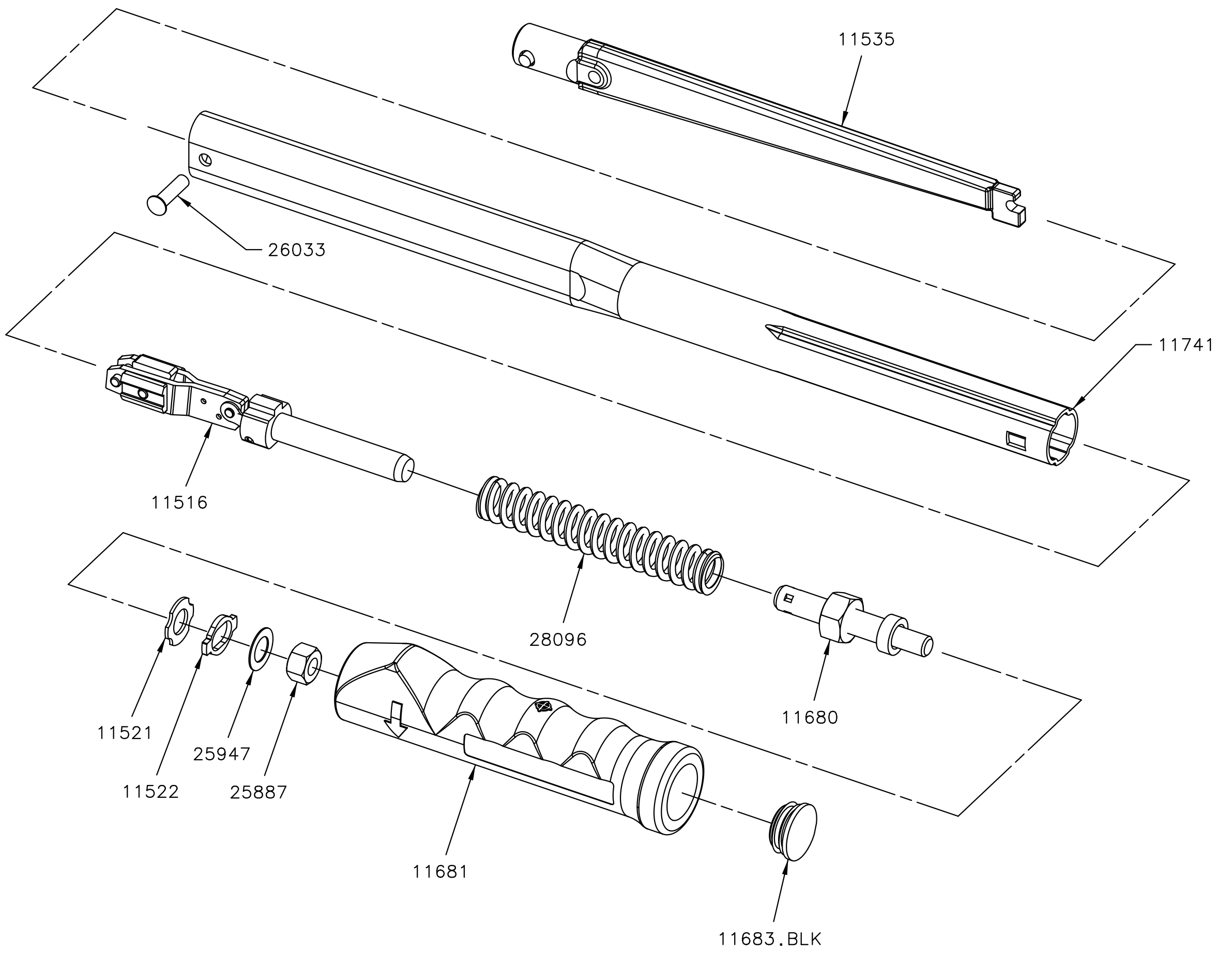

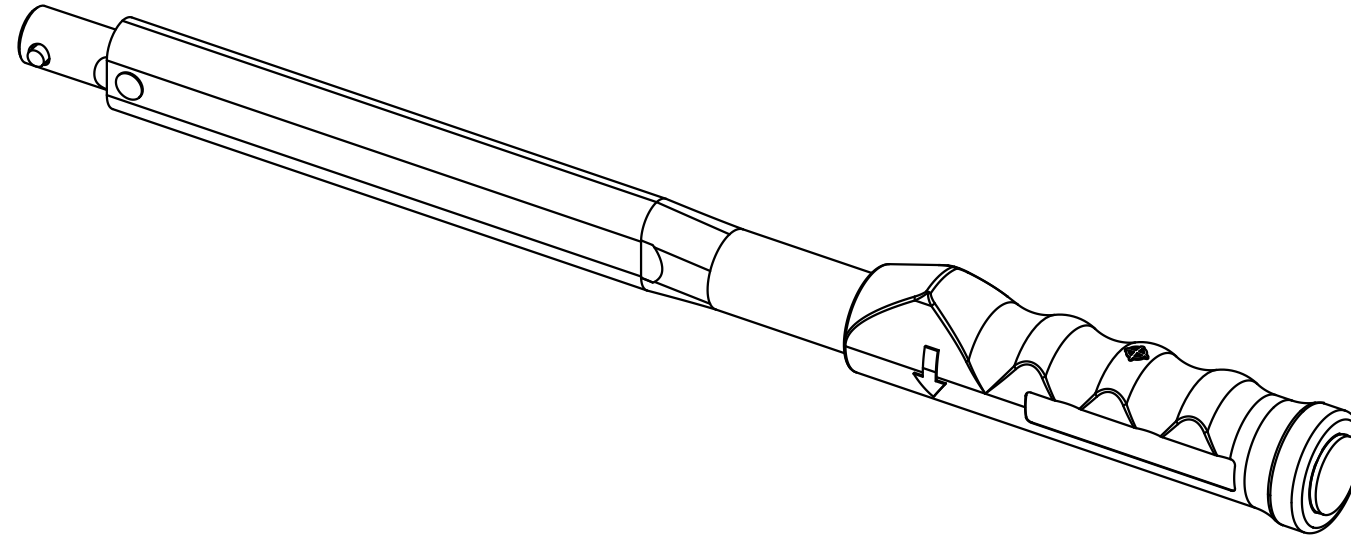

11516	1	TRANSVERSE LINK ASSY PROFESSIONAL
11521	1	SHAPED WASHER
11522	1	END STOP
11535	1	LVR ARM 200 T/H
11680	1	ADJUSTING NUT AND SCREW P TYPE THREADED END
11681	1	HANDLE P TYPE PRESS ON
11682	1	SOCKET 13mm AF FOR P TYPE PROFESSIONAL ADJUSTING
11683.BLK	1	END CAP DOMED P TYPE PROF BLACK
11741	1	MDL200 BODY TUBE
25887	1	HEX.NUT.M8 H.TEN.
25947	1	WASHER .39/.395 x .65 x .018 REF SR 126J
26033	1	PIVOT PIN TES 3487
28096	1	COMP. SPRING FOR TW MACHANISM
Part No	Qty	Description