

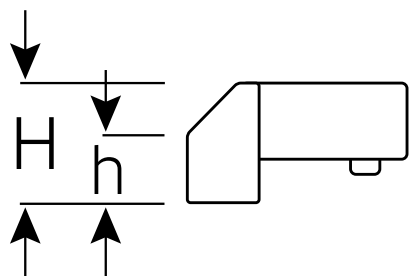

737/10

Blank end insert tool

gunmetal finish. To prevent damage from excessive temperatures, the locking pin, spring and washer are not fitted until the welding work has been completed. Instructions are supplied.

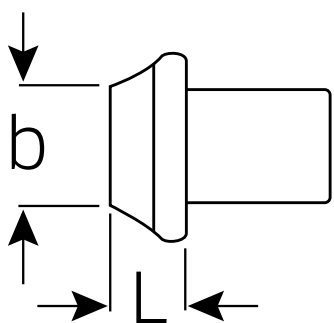



Code	Welding surface $h \times b$ mm	 mm	H mm	L mm	 g
58 27 00 10	8 x 14	9x12	14.5	8	35

737/40

Blank end insert tool

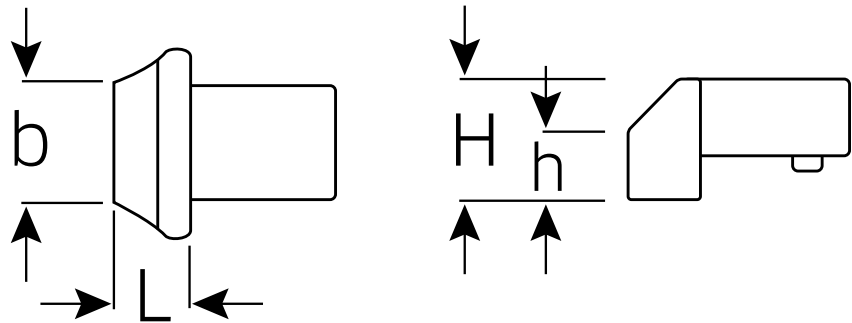
gunmetal finish. To prevent damage from excessive temperatures, the locking pin, spring and washer are not fitted until the welding work has been completed. Instructions are supplied.





Code	Welding surface h x b mm	 mm	H mm	L mm	 g
58 27 00 40	11 x 25	14x18	21.5	12	98

737/100

Blank end insert tool

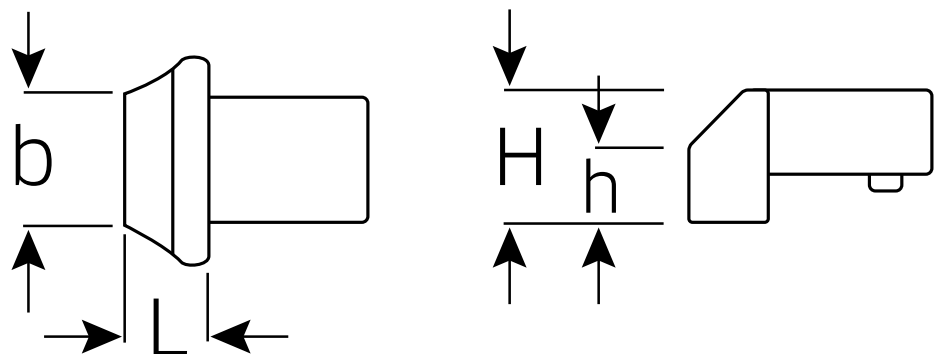
gunmetal finish. To prevent damage from excessive temperatures, the locking pin, spring and washer are not fitted until the welding work has been completed. Instructions are supplied.



Code	Welding surface h x b mm	 mm	H mm	L mm	 g
58 27 01 00	15 x 50	22x28	32	24	521