

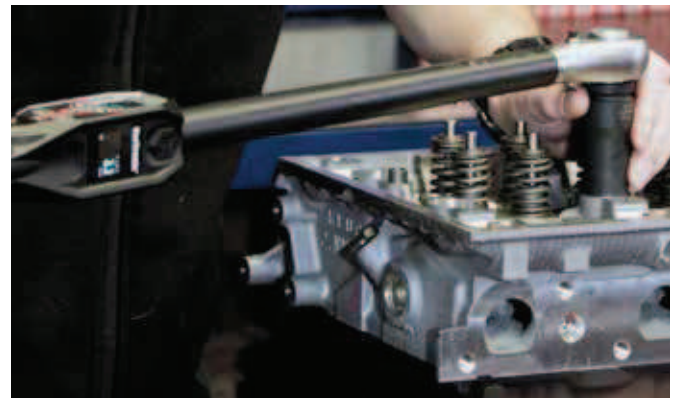

## NORTRONIC® ELECTRONIC TORQUE WRENCHES



The NorTronic®, our first electronic torque wrench, sets the benchmark with its unique Torque Data System (TDS) software and combination of accuracy, wireless capability and angle measurement, in a versatile, robust and easy to use package.

- Accurate and traceable torque and angle control
- Two full colour OLED displays positioned at 90° to each other for visual indication both horizontally and vertically
- 3 Models covering 5 N·m- 330 N·m
- IP44 protection against dust and water ingress
- One piece aluminium handle
- Extruded aluminium case
- Torque & Angle readings can be sent to TDS in real time or downloaded via the USB lead or wireless interface. For a wireless connection, a wireless adaptor is required for your PC. Each wireless adaptor can handle up to 8 wrenches
- Ability to interface to ProSuite process control software
- Calibration date of tool can be displayed via TDS or third party software
- ASCII mode allows for interfacing the Tool to third party software
- When used with a HandTorque® gearbox the NorTronic can directly display, save and send the output Torque of the HandTorque®
- Ability to set a Torque, Angle and Final Torque Target
- Ability to produce and save Torque & Angle graphs (in real time) from a USB connected tool
- Ability to have up to 15 linked or non-linked Targets on the tool at any one time
- Angle calibration in accordance with VDI/VDE 2648
- UKAS accredited Torque calibration in both clockwise and anti-clockwise direction



Compatible with Norbar's huge range of spanner end fittings

Unique Torque Data System software enables data management and archiving to a PC



NorTronic® DLL (Dynamic Link Library) Plugin enables NorTronic® tools to be interfaced to a customer's existing production line control software.

Contact Norbar for more details.





**NORTRONIC® ELECTRONIC TORQUE WRENCHES**



4 NORTRONIC® 868 MHZ	
43500	NorTronic® 50, 3/8" sq. dr., 868 MHz, 5 - 50 N-m
43501	NorTronic® 50, 1/2" sq. dr., 868 MHz, 5 - 50 N-m
43502	NorTronic® 200 1/2" sq. dr., 868 MHz, 20 - 200 N-m
43503	NorTronic® 330, 1/2" sq. dr., 868 MHz, 33 - 330 N-m
43508	USB Wireless Adaptor, 868 MHz

For UK, Europe, Singapore and India

4 NORTRONIC® 915 MHZ	
43504	NorTronic® 50, 3/8" sq. dr., 915 MHz, 5 - 50 N-m
43505	NorTronic® 50, 1/2" sq. dr., 915 MHz, 5 - 50 N-m
43506	NorTronic® 200, 1/2" sq. dr., 915 MHz, 20 - 200 N-m
43507	NorTronic® 330, 1/2" sq. dr., 915 MHz, 33 - 330 N-m
43509	USB Wireless Adaptor, 915 MHz

For USA, Canada, Australia and New Zealand

Model	NorTronic® 50 3/8"	NorTronic® 50 1/2"	NorTronic® 200 1/2"	NorTronic® 330 1/2"
Part Number/s	43500 43504	43501 43505	43502 43506	43503 43507
Dimensions (mm)	A	468	472	592
	B	449	449	569
	C	34	45	45
	D	41	41	41
	E	223	223	223
	F	35	35	35
	G	388	388	508
	ØH	38	46	46
	I	42	42	42
Weight (Kg)	1.20	1.20	1.45	1.86

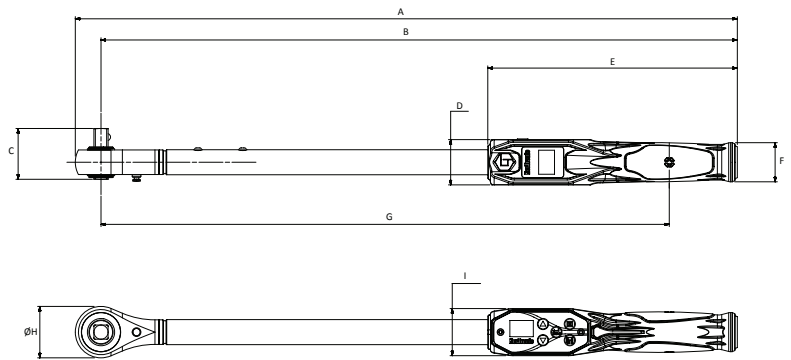

**INSULATED TORQUE WRENCH**



Using injection moulded Nylon 11, Norbar's insulated torque wrench complies with IEC 60900:2004 and is more durable than the traditional PVC dipped insulated tools. Certified to 1000 volts.

4 ADJUSTABLE - DUAL SCALE	
13870	TT60 3/8" Insulated 12 - 60 N-m, 8 - 44 lbf-ft
13871	TT60 1/2" Insulated 12 - 60 N-m, 8 - 44 lbf-ft

Model	All Models	
Part Number/s	13870 13871	
Dimensions (mm)	A	350
	B	328
	C	234
	ØD	44
	E	80
	F	65
Weight (Kg)	0.9	

